

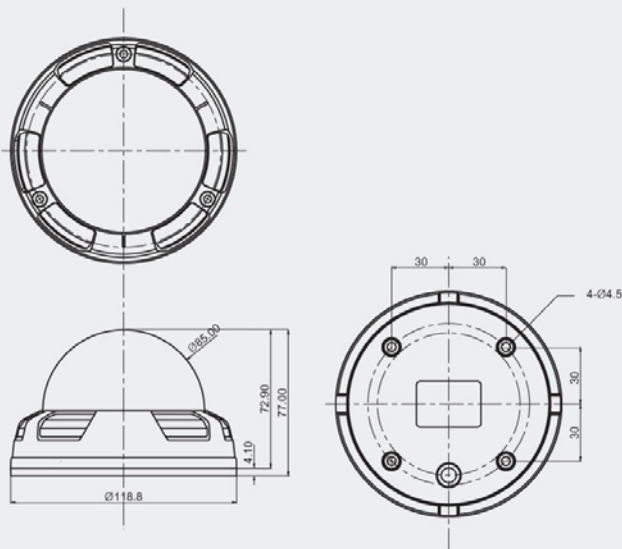

## Features

- 1/3 inch IT CCD
- Ultra High Resolution : 600 TV Lines
- Built in Fixed Lens (f=3.8mm)
- Min. Illumination : 0.05 Lux
- Auto White Balance
- AGC, BLC
- Extra Video Out Port for Installer
- 3-Axis Movement for Free Lens Rotation
- Vandal-Resistant Dome Housing
- Diameter of Bubble : 85mm
- IP65

## DIMENSIONS



## SPECIFICATIONS

Model	VFL-20S	VFL-21S
Signal System	NTSC	PAL
Scanning System	2:1 Interlace	
Scanning Frequency (H)	15.734 KHz	15.625 KHz
Scanning Frequency (V)	59.94 Hz	50 Hz
Image Sensor	1/3 Inch IT CCD	
Total Pixels	811(H) x 508(V) 410K	795(H) x 596(V) 470K
Total / Effective Pixels	768(H) x 494(V) 380K	752(H) x 582(V) 440K
Horizontal Resolution	600 TV Lines	
Video Output	1.0V p-p (75Ω, Composite)	
S/N Ratio	More than 48dB(AGC Off)	
Lens	Fixed Lens (f=3.8mm)	
Min.Illumination	0.05 Lux	
White Balance	Auto	
AGC, BLC	Auto	
Shutter Speed	1/60~1/120,000 sec.	1/50~1/120,000 sec.
Supplied Voltage	DC 9V~15V (Recommendation DC±0.5V)	
Power Consumption	Max.150mA	
Dimensions(ØxH)	85Φ x 77(H) mm	
Operating Temperature	-10°C~45°C / Humidity 30%~80% RH	
Weight	Approx. 376g	